

Pland

MADE IN
BRITAIN



Strength in stainless steel

Pland Stainless has become an expert in the production and supply of Hospital Scrub up troughs for the health service. It is one of the few UK manufacturers to produce them and is now the UK market leader in this specialist area.

Scrub-up troughs are spacious wash basins that enable surgeons and nurses to wash and scrub their hands and forearms before and after medical procedures.

Guide to Hospital Scrub up Troughs

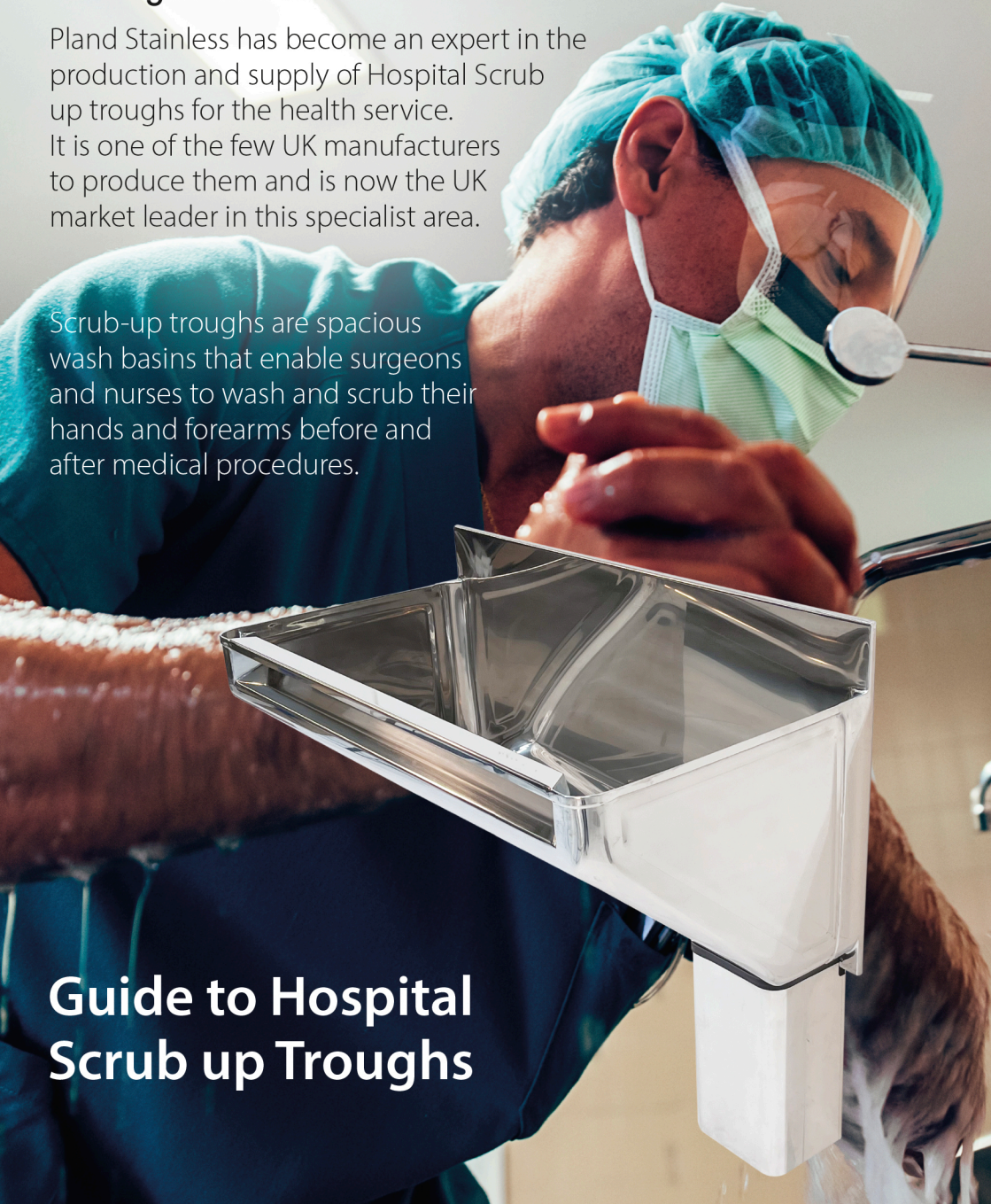

If you are specifying this product for the healthcare sector there are a few pointers to be aware of. Requirements for scrub-up troughs vary, and Pland manufacture many bespoke options. We have two standard options, in a variety of sizes, that comply with the standard required for NHS England :

HTM64

HBN0010 Part C

Many healthcare specifiers and providers throughout the UK have now adopted these specifications, and we regularly supply models to meet these standards.

The **HBN** (Health Building Note) allows choice in the materials and methods of construction – provided they satisfy the performance requirements that it outlines. The material used should be suitable for its intended location (for example, stainless steel in kitchens and hygienic surfaces in labs).

QIPP (Quality, innovation, productivity and prevention) within the standard also requires improving quality whilst achieving value for money. Key to the requirements here are the parameters surrounding infection prevention and control. When selecting a scrub-up trough, it is important to involve the Infection prevention and control teams before making a selection.

Finishes should be chosen with cleaning in mind, especially where contamination with blood or body fluid is a possibility (that is, smooth, non-porous and water resistant).

They are both manufactured with the same quality and care. But the specifications differ. Pland offers two versions of the scrub up trough the “Trinidad”, and the “Sola”.

- **Trinidad** is our premium model and takes around 15 hours of production to complete.
- Manufactured from 304 grade, 1.5mm steel.
- Fabricated with pressed ends to maintain rigidity of the end panel and to aid cleaning. The end is pressed on a 5,000 tonne press to retain the strength in the product.
- All internal welds are cleaned and polished seamlessly to ensure hygiene in theatre conditions.
- The waste is welded into the product and a depression ensures full drainage of the product, so no residual water remains.
- A lipped edge at the top returns outwards and is then flattened on the outside to provide a safe edge when cleaning.
- The trough is supported on the wall/panel by a hidden fixing along the top rail.
- The product is bright polished throughout and the design is crack/ crevice free.
- The rear of the trough is radiused and all welds are bright polished and smooth with an integral anti-splash mould built into the design.
- There are no visible weld lines inside of the trough.

- **Sola** has been designed specifically to be made quickly, cutting the production time in half and thereby reducing the cost. It is still compliant with the standard, and manufactured from the same 304 grade, 1.5mm stainless steel, but it has a different construction:
- The ends are flat material and the front edge is returned with a safety edge concealed within the trough.
- The ends are welded on fully and the weld is cleaned, though it is still visible as a weld and requires more thorough cleaning.
- The trough is supported on the wall/panel with a hidden fixing.
- The waste is also welded in to ensure full drainage.

Lead times vary...

The lead times are another determining factor as they differ hugely especially with production capacity changing daily.

If ordering for a new hospital, it's not uncommon for orders to exceed 50 troughs and for the premium Trinidad version lead times can be stretched to 12 weeks due to the manufacturing process and the labour required.

The budget Sola version is available in around 2-3 weeks from date of order.

Trinidad



Sola

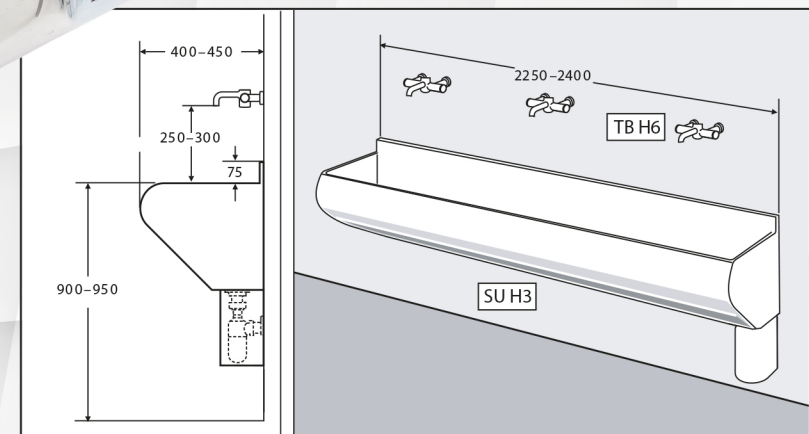

Popular Healthcare Products

We've been manufacturing stainless steel products for over 100 years. We make our products in Leeds and offer a speedy delivery to our UK customers. Check out these popular selling healthcare lines.



PENANG
plaster Sink



JERSEY
sit on sink



FIJI
slop hopper



SAMOA
janitorial sink



Visit our website by
scanning this QR code.